

**A NUMERICAL METHOD TO PREDICT VELOCITY DISTRIBUTION AND  
HEAT TRANSFER IN A CYLINDER HEAD OF AN I.C.E. WITH SWIRL**  
طريقة تحليلية لحساب توزيع السرعات والحرارة المنقولة من رأس الاسطوانة لمحرك احتراق  
المكبسي راجعاً التكامل لمعادلات انتقال الحرارة المعروفة والمستنتجة عملياً ، والطريقة  
التي اتبعت في هذه الدراسة هي طريقة الفروق المحددة. يفرض الدوامية الحرة مع وجود قلب  
دائر على محور صمام السحب وهذه تمثل الحالة أثناء متوار السحب حتى نهايته . وتم  
كذلك ايجاد ضغط الصدمة ومعدل تغيره بالنسبة للزمن وفي هذه الدراسة تم ايجاد الحد  
بعد الحد الثالث في طريقة الحل الرياضي بالفروق المحددة . تم كذلك في هذه الدراسة  
الآخذ في الاعتبار هفاقيد الاحتكاك واللزوجة . والنتائج التي حصلنا عليها اوضحت أن توزيع  
السرعات غير مستقر بعد 8 أو 9 فترات زمنية وهذا يمكن أن يكون نتيجة للخطأ المتراكم  
فغرضنا فرق محدد ويمكن تلاشي هذا الخطأ بفرض 6 نقط بدلاً من 4 وان كان هذا يزيد من  
الزمن المستغرق في حل البرنامج على الحاسب الآلي . والنتائج التي حصل عليها في الحرارة  
المنقولة خلال المكبسي أثناء متوار التمدد متفق مع النتائج المتوافرة في هذا المجال.

**ABSTRACT-** To determine the heat transferred to the piston and the cylinder head of an I.C.E. ,the velocity distribution in the cylinder head is required. The work presented in this paper aims at producing this distribution by numerical method. Once this distribution is determined ,the heat transfer can be evaluated by a double integration.

The method chosen in this study is to assume a free vortex condition with a solid rotating core. This is considered to represent the conditions that would prevail at the end of the induction stroke. The finite difference method is used to solve the differential equations. For this analysis it is decided to neglect 3rd order differences and above. It is also decided to fit parabolas over any three adjacent points.

A method is also devised to determine the stagnation pressure at one time interval from the stagnation pressure at past time intervals and  $(dF_{stag}/dt)$  for the previous interval. The results obtained showed that the velocity profile becomes unstable after 8 or 9 time steps. This is probably due to accumulation error, may be from the 1% difference allowed. The simplest way to overcome this would be to use more radial steps and smooth the curve over group say 6 points instead of 4 points. However, this would increase the run time on the computer.

### 1-INTRODUCTION

Calculation of the heat transfer and prediction of the thermal performance of combustion systems are of great importance, particularly with regard to fuel economy. The results of these calculations can be used either to improve the thermal efficiency of existing engines or to design new engine. This investigation is an attempt to estimate the heat transferred from the gases in an engine cylinder to the cylinder head and piston crown. It is known that during the induction stroke the gases in the cylinder are swirl due to the tangential velocity of the incoming gases, the true values of velocity in the cylinder are not known. Measurement

of gases velocities in the cylinder throughout the cycle is very difficult. The response of any instruments used to measure velocities must be very rapid as the conditions are always changing. The hot wire anemometer cannot be used directly as temperature in the cylinder changes with compression and combustion. The most suitable experimental method would appear to be a photographic one. Particles carried by the gases and made visible could be photographed through a transparent cylinder head. The experimental difficulties would be great.

Experimental results are available for the heat transfer from a stationary gas to a rotating disc[1]. This study assumes that the gas is rotating with constant angular velocity throughout the cylinder and that this velocity is constant for a given engine speed throughout the cycle. Experiments on cyclone separators[2] and some direct readings of gas velocities during the induction and compression strokes of a compression ignition engine[3,4] show that the gas in the cylinder will not rotate with constant angular velocities. These results tend to suggest that the flow pattern at the start of compression is made up of two parts, i- A constant angular velocity rotating central core and ii- An outer annulus in which the flow is very close to free vortex.

From the work done on a rig in which air enters a heated cylinder tangentially at the outer radius and leaves through a pipe at a center of the cylinder, Yadov[13] obtained an empirical expression for pressure loss due to friction and for heat transfer coefficient between the cylinder ends and the swirling gas. The present work aims to produce a computer programme to work out the instantaneous velocity profile across a radius of the cylinder at intervals of angular crank movement and use an available empirical expression for the heat transfer coefficient to work out the heat transferred to the piston crown and to the cylinder head of an I.C.E.

## 2-MODEL DESCRIPTION

As a first attempt for obtaining a velocity profile it is assumed an idealized model. This model is based on two assumptions. In the first assumption, the gases already in the cylinder at the start of induction are, a central cylinder with radius equal to the radial distance of the inlet valve, and an outer annulus as shown in Fig.(1). As the piston moves down the cylinder there is very little change in temperature and pressure, so these values can be considered constant during the induction stroke. The gas entering through the valve then separates the two parts, the inner cylinder staying as a cylinder elongating with the piston movement and decreasing in diameter, and the outer annulus staying by the cylinder wall increasing in length and decreasing in thickness.

The second assumption is that the flow into the cylinder is from an idealized very thin hollow cylindrical source. It is the one separating the cylinder and the annulus mentioned in the first assumption. The tangential velocity from the ideal cylinder is equal to that of the gases in the inlet port.

Another flow pattern may be considered is that in which the incoming air forms layers within the cylinder. Consideration of this flow pattern is discontinued as the vertical component of the air would force it to mix in a vertical direction. A truer explanation of the flow would somewhere between the two patterns, allowing for some variation in vertical velocity distribution. Such a pattern would be difficult to analysis, so the first model is the one

used in this investigation.

The losses incurred by what we considered "turbulent mixing" friction is given in terms of loss in total head or "stagnation" pressure. It is also allowed for viscous losses due to the velocity gradients which are given in terms of loss of total head pressure also. Because of this, a form of the Navier Stokes equation is not suitable. The density of the gas is assumed to be constant with respect to the radius at any time instant. This assumption is justified as the maximum velocity is about 100 m/s, given a velocity head,  $\frac{1}{2}\rho u^2$ , of  $5 \times 10^3$  N/M<sup>2</sup> compared with atmospheric pressure of  $10^5$  N/M<sup>2</sup>. Another assumption is that the bulk temperature and pressure are only affected viscosity, density and conductivity and did not have a direct influence on the flow.

### 3-NUMERICAL METHOD

The method chosen in this analysis is to assume a free vortex condition with a "solid" rotating core. This is considered to represent the conditions that would prevail at the end of the induction stroke. The free vortex condition is based on the mean inlet velocity although, this will tend to give an excessively high value towards the centre. The general assumption of this condition is seems to be reasonable in view of the results obtained in the references mentioned. The finite difference method is used to solve the differential equations. During this study it is decided to neglect 3rd order differences and above. This seemed to be a reasonable compromise between the number of points needed and the complexity of the derived equations. Instead of working with difference tables it is decided to "fit" parabolas over any three adjacent points. The use of parabolas is justified by comparing the number of points required to get the same accuracy from a mid-ordinate rule integration as from a Simpson's rule integration. The first part of the solution is to find a method to deduce the velocity profile. The mathematical development of the flow pattern is discussed next. A method is also devised to determine the stagnation pressure at one time interval from the stagnation pressure at past time intervals and  $(dP_{stag}/dt)$  for the previous interval. However, the conditions are not known for the first time intervals, so a starting procedure has to be devised as well. The method used is basically the classic iterative procedure of solving equations of the form  $f(x)=0$ , for  $x$ , " $x$ " in this case being a "surface" and not a single value. The equation is written as  $x=g(x)$  and thus  $x_{n+1}=g(x_n)$  where  $x_{n+1}$  is a better approximation of  $x$  than  $x_n$ . The application is a little complex as we are working in terms of profiles rather than just one discrete value. The problem with this method is that it can sometimes be unstable, but is the simplest method.

An alternative would be a method based on Newton Raphson, ie.

$$\begin{aligned} x_{n+1} &= x_n - f(x_n)/f'(x_n) \\ &= x_n - 2hf(x_n)/[f(x_n+h)-f(x_n-h)] \end{aligned}$$

Where  $h$  is some suitably chosen small value. However, this would be more difficult to programme than the first method. With repeated application of a parabolic approximation to the profile it is possible for accumulative error to build up, so a smoothing technique is used.

4-DERIVATION OF EQUATIONS OF MOTION

Within the limitations of the physical model described, the governing equation of motion may be obtained as following, referring to Fig. 2

Let  $Z_T$  be the distance between the piston and the cylinder head at T.D.C.

Volume of air enclosed within radius  $r_0$  at TDC =  $\pi r_0^2 Z_T$

Radius of this volume of air when distance between piston and cylinder head is  $Z$ ,  $r = r_0 \sqrt{Z_T/Z}$

Volume of air enclosed within  $r_0 - r$  when the piston is at TDC is,

$$\pi(r_0^2 - r^2)Z_T$$

Hence, radius of this volume of air when the distance between the cylinder head and the piston is  $Z$ ,

$$r = \sqrt{r_0^2 - (r_0^2 - r_0^2)Z_T/Z}$$

For  $r < r_0$ , flow across at radius  $r$ ,  $q_r = \pi r^2 Z_T$

$$v_r = -q_r / 2\pi r Z = -r/2 (Z_T/Z)$$

For  $r_0 < r < r_0$ , flow across element =  $q_r = \pi(r_0^2 - r^2)Z$

$$v_r = [(r_0^2 - r^2)/2r] * (Z_T/Z)$$

Consider an elemental hollow cylinder, part in which shown in Fig.3. The of element  $\approx [2\delta r * r \delta \theta$

Considering the balance of pressure force and inertia forces, the net inward pressure force;

$$= [2[(r + \delta r/2)\delta \theta(P + \delta P/\delta r * \delta r/2) - (r - \delta r/2)\delta \theta(P - \delta P/\delta r * \delta r/2)] - 2ZP\delta r \text{ Sin}\delta \theta/2$$

If  $\delta \theta$  is small,  $\text{Sin}\delta \theta/2 \approx \delta \theta/2$

$$2ZP\delta r \text{ Sin}\delta \theta/2 \approx ZP \delta \theta * \delta r$$

and net inward pressure force;

$$= Z\delta \theta [(rP + r\delta P/\delta r * \delta r/2 + P\delta r/2 + \delta r^2/4\delta P/\delta r) - (rP - r\delta P/\delta r * \delta r/2 - P\delta r/2 + \delta r^2/4\delta P/\delta r) - P\delta r] = Z\delta \theta r \delta P/\delta r * \delta r$$

Acceleration of element towards centre =  $v_r^2/r - \delta v_r/\delta t$

From Newton's second law, force = mass \* acceleration

$$\delta P/\delta r = [v_r^2/r - \delta v_r/\delta t] \tag{1}$$

Where,  $v_\theta$  and  $v_r$  are the tangential and radial velocities respectively. Partial derivatives are used because all variables are time and space dependent.

From Bernoulli's equation, the stagnation pressure;  $P_{stagn} = P + \frac{1}{2}\rho v^2$  where  $v = \sqrt{v_\theta^2 + v_r^2}$  is the absolute velocity of the element.

The losses which are considered to reduce the stagnation pressure, as far as the flow pattern is concerned, are assumed to come only from two sources, these being viscosity and friction drag respectively.

**4-1 The Losses Due To Viscosity**

Consider an elemental hollow cylinder, part of which shown in Fig. 4;

Mass of element =  $2\pi r \delta r Z$  and moment of inertia,  $I = 2\pi r^3 \delta r Z$

Torque on element =  $2\pi (r + \delta r/2)^2 Z (\tau + \delta \tau / \delta r * \delta r/2) - 2\pi (r - \delta r/2)^2 Z (\tau + \delta \tau / \delta r * \delta r/2)$

$$= 2\pi Z [(r^2 + r\delta r + \delta r^2/4 - r^2 + r\delta r - \delta r^2/4) \tau + \delta \tau / \delta r * \delta r/2 (r^2 + r\delta r + \delta r^2/4 + r^2 - r\delta r + \delta r^2/4)]$$

$$= 2\pi Z [2r\delta r + \delta \tau / \delta r * \delta r/2 (2r^2 + \delta r^2/4)]$$

$$= 2\pi Z \delta r [2r\tau + \delta \tau / \delta r (r^2 + \delta r^2/2)]$$

But, torque =  $\omega * I = v_w / r * I$

$$1/r * \delta v_w / \delta t * 2\pi r^3 \delta r Z = 2\pi Z \delta r [2r\tau + \delta \tau / \delta r (r^2 + \delta r^2/2)]$$

$$\rho / r * \delta v_w / \delta t = 2\tau / r + \delta \tau / \delta r$$

By definition  $\tau = \mu * \delta v_w / \delta r$

$$\delta \tau / \delta r = \mu \delta^2 v_w / \delta r^2$$

Substituting in above equation, gives;

$$\delta v_w / \delta t = \mu / \rho r (2\delta v_w / \delta r + r \delta^2 v_w / \delta r^2)$$

$$P_{stagn.} = P_{static} + \frac{1}{2} \rho v^2$$

$$\delta P_{stagn.} / \delta t = \delta(\text{velocity head}) / \delta t + \delta P_{static} / \delta t$$

$$= \delta [ \frac{1}{2} (v_w^2 + v_r^2) ] / \delta t + \delta P_{static} / \delta t$$

$$= \frac{1}{2} (v_w^2 + v_r^2) \delta \rho / \delta t + \rho / 2 (2v_w \delta v_w / \delta t + 2v_r \delta v_r / \delta t) + \delta P_{static} / \delta t$$

But,  $\delta v_w / \delta t = \mu / \rho r (2\delta v_w / \delta r + r \delta^2 v_w / \delta r^2)$

$$\delta P_{stagn.} / \delta t = \frac{1}{2} (v_w^2 + v_r^2) \delta \rho / \delta t + \rho [v_w^2 / \rho r (2\delta v_w / \delta r + r \delta^2 v_w / \delta r^2) + v_r \delta v_r / \delta t] + \delta P_{static} / \delta t$$

I.e the rate of loss in stagnation pressure due to viscosity is;

$$\delta P_{stagn.} / \delta t = \frac{1}{2} (v_w^2 + v_r^2) \delta \rho / \delta t + [v_w \mu / r (2\delta v_w / \delta r + r \delta^2 v_w / \delta r^2) + v_r \delta v_r / \delta t + \delta P_{static} / \delta t]$$

**4-2 Friction Losses**

Yadov's [1] has obtained an empirical relationship on vortex flow transfer as;

$$\delta P_{stagn.} = -f \rho v^2 / 2 * \delta l / d$$

In this case  $d = Z$ ,  $f$  is a factor,  $\delta l$  is the length travelled =  $v \delta t$

$$\delta P_{stagn.} / \delta t = -f \rho v^3 / 2Z$$

However,  $f = k/R_m^n = k(\mu/\rho Z)^n v_m^{n-1}$

Where  $R_m$  being a Reynold's number which for this calculation should be based on  $v = \sqrt{v_o^2 + v_r^2}$ ,  $k$  and  $n$  are constants given in reference[1].

$$\delta P_{\text{visc}} / \delta t = -k(\mu/\rho Z)^n \rho / 2Z (v_o^2 + v_r^2)^{(n-1)/2}$$

Therefore, viscosity and friction losses together gives,

$$\delta P_{\text{visc}} / \delta t = \frac{1}{2} (v_o^2 + v_r^2) \delta f / \delta t + (v_o \mu / r) (2 \delta v_o / \delta r + r \delta^2 v_o / \delta r^2) + (v_r \mu / r) (\delta v_r / \delta t) - k(\mu/\rho Z)^n \rho / 2Z (v_o^2 + v_r^2)^{(n-1)/2} + \delta P_{\text{visc}} / \delta t \quad (3)$$

But from equation(1)  $\delta P / \delta r = \rho (v_o^2 / r - \delta v_r / \delta t)$

$$\text{Thus, } P = \int_{r_o}^r [\rho (v_o^2 / r - \delta v_r / \delta t)] dr$$

$$\text{and } \delta P / \delta t = \delta / \delta t \int_{r_o}^r [\rho (v_o^2 / r - \delta v_r / \delta t)] dr$$

Substituting in the differential form equation(3) gives the following differential equation of motion;

$$\delta P_{\text{visc}} / \delta t = \frac{1}{2} (v_o^2 + v_r^2) \delta f / \delta t + (v_o \mu / r) (2 \delta v_o / \delta r + r \delta^2 v_o / \delta r^2) + (v_r \mu / r) (\delta v_r / \delta t) - k(\mu/\rho Z)^n \rho / 2Z (v_o^2 + v_r^2)^{(n-1)/2} + \delta / \delta t \int_{r_o}^r [\rho (v_o^2 / r - \delta v_r / \delta t)] dr \quad (4)$$

If only compression and expansion strokes are considered, equation (4) reduces to;

$$\delta P_{\text{visc}} / \delta t = \frac{1}{2} v_o^2 \delta f / \delta t + v_o \mu / r (2 \delta v_o / \delta r + r \delta^2 v_o / \delta r^2) - k(\mu/\rho Z)^n \rho / 2Z \int_{r_o}^r (v_o^2 / r) dr \quad (5)$$

With the necessary boundary conditions the equation should be solved for  $v_o$ . Thus with knowledge that the instantaneous rate of heat transfer,  $DQ$  is;

$$DQ = 2\pi \int_0^b h(T_o - T_w) r \cdot dr$$

Where  $h$  is the localized heat transfer coefficient. Using Yadov's expression[1];

$$Nu = \frac{hd}{K} = \frac{(R_m / 60000)^{0.8} [(16.29 - (r/d)^2)^2 + 5.62(r/d)^2]^{0.4}}{7.485(1 - 1.1475(r/d) + 0.06744(r/d)^2 + 0.000906(r/d)^3) + 4.47 - 2.92469(r/r_o - 1/3)^2 / (r/r_o)}$$

Once to integrate these instantaneous values to the heat transferred during the expansion stroke can be obtained as;

$$Q = \int_0^{180} \dots d\theta$$

### 5-RESULTS AND DISCUSSIONS

Essentially the need for this analysis arises from the fact that the engine heat loss needs to be predicted for the various cycle strokes. To do this we need to be able to predict for various instants throughout the cycle the localized heat transfer coefficient at each point on the piston crown. These values can then be integrated to give an overall heat transfer coefficient,

and this in turn gives an instantaneous rate of heat transfer. If this process is repeated for several instants during the cycle then all the instantaneous rates of heat transfer can themselves be integrated to give the total heat transferred for that part of the cycle.

As a first stage of this model development the results are obtained only for heat transferred to the piston crown during the expansion stroke as this was considered to be the most interesting as far as heat transfer is considered. The Simpson integration procedure which is used a total of eleven times in the program, i.e. 10 times to integrate the localized heat transfer coefficients to give the instantaneous rate of heat transfer and once to integrate these instantaneous values to give the total heat transferred during the expansion stroke. A 20 degree intervals of crankangle from 0 to 180 are adopted and the various engine variables are calculated. The gas temperature at the particular part of the cycle is taken from ideal Diesel cycle program output and the viscosity and thermal conductivity are calculated. The working fluid is assumed to be air.

As the program stands it assumes that the velocity profile within the cylinder remains constant. The profile is induced on the induction stroke and assuming that the tangential components of velocity are conserved with respect to the change in cylinder volume. As can be seen from the results presented in Fig.(5), the velocity profile becomes unstable after 8 or 9 time intervals, this is probably due to accumulation error, may be from the 1% difference allowed. The simplest way to overcome this would be to use more radial steps and smooth the curve over group of, say 6 points instead of 4 points. However, this would increase the run time on the computer. The stagnation pressure and  $dP_{stag}/dt$  behaviours during the intake stroke at different crankangles positions are shown in Figs.(6&7). These results show immediately that even on the intake stroke, effects are to be of greater significance.

Fig.(8), show the localized value of heat transfer coefficient at various radii on the piston crown. The number of points are determined by the bore radius. The value of  $h$  determined is found depends on two factors;

- 1) The Reynold's number factor ( $Re_r$ ) which is depends on the velocity at each radius and the velocity profile assumed. The form of the profile assumed is shown in Fig.(9). The curved part of the graph represents a free vortex.
- 2) The combustion turbulence term which is not applicable until combustion has started. The time at which this term is applied is in compression ignition engines, the time of maximum temperature expressed as a crankangle. As already mentioned this term decays with time for times greater than .005 sec. Below this time the value of  $h$  as regards combustion turbulence is not accurately known and thus the value at .005 sec. is taken.

The timing is decided by the formula,  $t = (60*(CA-MT))/(RPM*360)$   
Where CA is the crankangle and MT is the angle of maximum temperature.

Fig.(10) shows the calculated heat losses by integrating the instantaneous rate of heat transfer. It can be seen from the figure that the calculated results are lower than the available experimental data [5]. This could be due to a number of reasons. As we know the correct temperature profile would alter the results and the shape of the graph. Also flame velocity has been estimated but this occurs in the combustion turbulence term which has a small contribution to the overall heat transfer coefficient.

## 6-CONCLUSIONS

This paper has presented the first attempt calculations of velocity distribution and heat transfer in a cylinder head of an internal combustion engine with swirl. The results and the methodology are of importance to the application of computational heat losses from the internal combustion engines problem. Among the results obtained;

- 1)The iterative method used in these calculations was unstable for the application. In fact the complex Newton Raphson method should have been used.
- 2)The assumption of a free vortex at the end of the induction stroke was unstable. The losses would have prevented such high velocities near the centre.
- 3)Velocity profile predicted becomes unstable after 8 or 9 time steps. This is probably due to accumulative error, may be from the 1% difference allowed.
- 4)The calculated heat losses from the piston crown during the expansion process are lower than the available experimental data. However, the correct temperature profile would alter the results
- 5)Although strictly inapplicable because of phase lag between gas temperature change and heat flux variation, the concept of instantaneous heat transfer coefficients can be used successfully in the analysis of heat transfer in reciprocating engines.

## NOMENCLATURE

h	Convective heat transfer coefficient	cal J/m <sup>2</sup> .hr.K
K	Thermal conductivity	cal J/m.hr.K
P	Pressure	
Q	Heat transfer rate	
Nu	Nusselt number	
Re	Reynold number	
r	radius	
T <sub>g</sub>	Gas temperature	K
T <sub>s</sub>	Surface temperature	K
v	velocity	
μ	Dynamic viscosity	
ρ	Density	
θ	Angular timing	(crankangle)

## REFERENCES

- 1-N.F.Yadav,"A Study of The Convective Heat Transfer Between a Fluid in a Vortex Motion and The Containing Surface", Ph.D Thesis Leeds University, U.K,1969
- 2-W.J.D.Annand,"Heat Transfer in The Cylinder of Reciprocating Internal Combustion Engines", Inst. of Mech. Engrs.,vol.177 No36 1936.
- 3-E.R.Esmael,"Spatial Variation of Heat Transfer in Swirl Combustion Chamber", M.Sc. Thesis, El-Mansoura University, 1979
- 4-M.D.Griffin,J.D.Anderson and E.Jones,"Computational Fluid Dynamic Applied to Three Dimensional Nonreacting Inviscid Flows in an Internal Combustion Engines",Journal of Fluid Engr.vol.101,1979
- 5-P.K.Betts and Y.K.Yue,"Vortex Flow in a Cylinder",Proc. Inst. of Mech. Engrs. 69/70



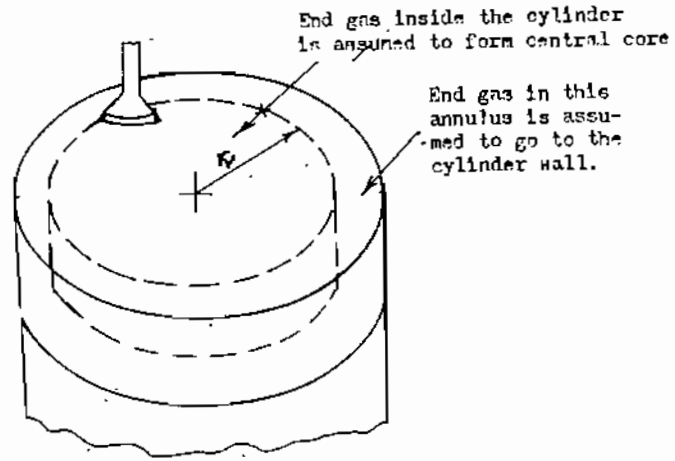

Fig.(1)

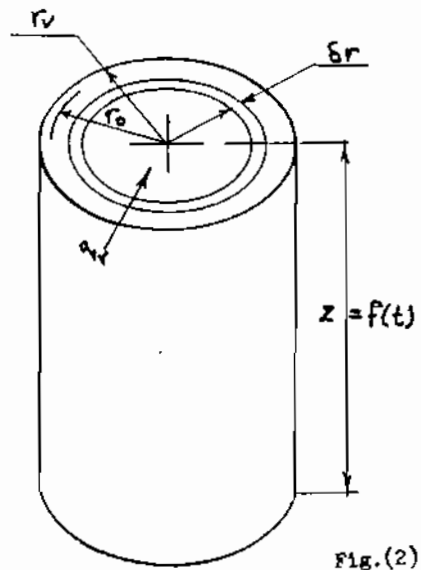

Fig.(2)

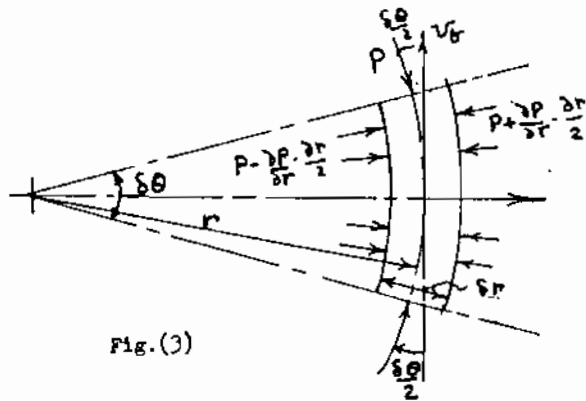

Fig.(3)

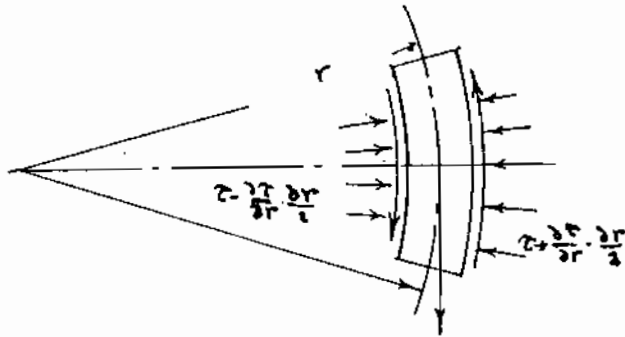

Fig.(4)

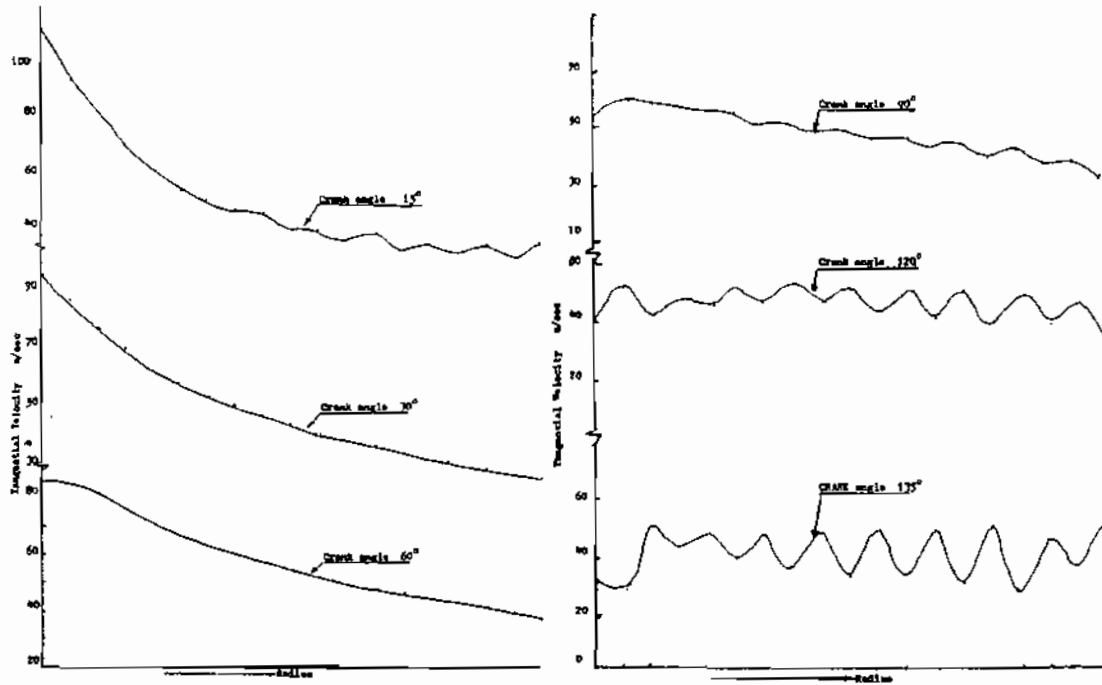

Fig.(5) Velocity Profiles at Different Crank Angles

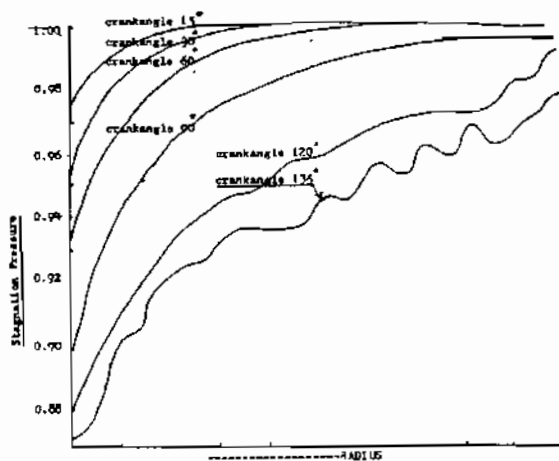

Fig.(6) Stagnation Pressure Profiles at Different Crank Angles

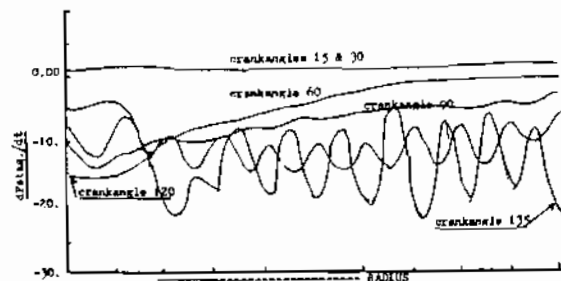

Fig.(7)  $dP_{stag.}/dt$  Profiles at Different Crank Angles

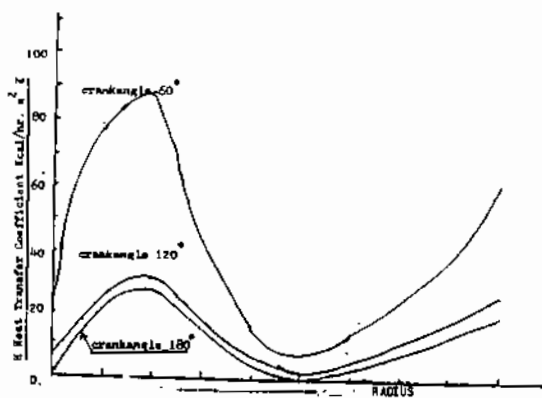

Fig.(8) Localized Heat Transfer Coefficient at Different Crank Angles

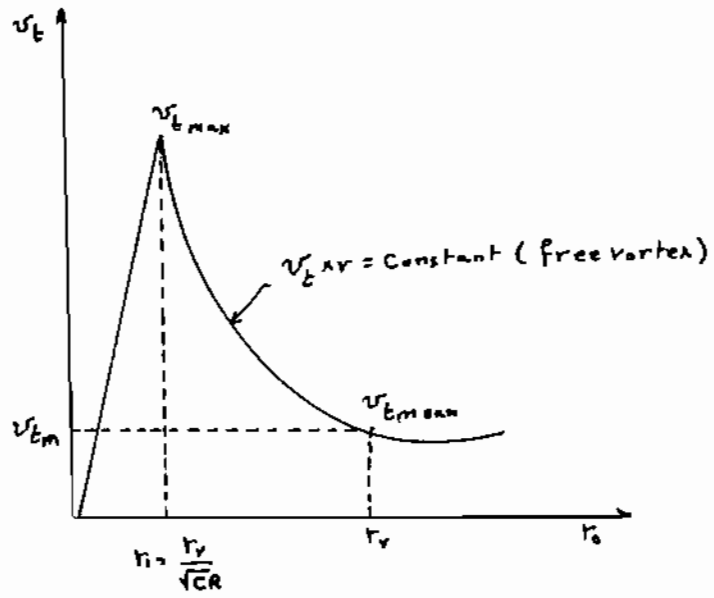

Fig.(9)

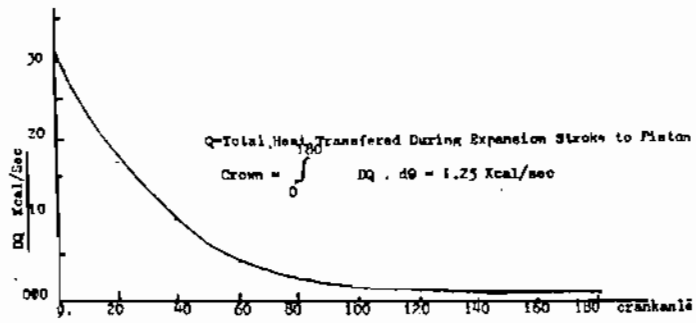

Fig.(10) Instantaneous Heat Transfer Rate to Piston Crown